

Grease Nipple
R1/8"A Type (Back Side)

>Description
SW Special Wheel
SW-180-I Type
Unit = mm

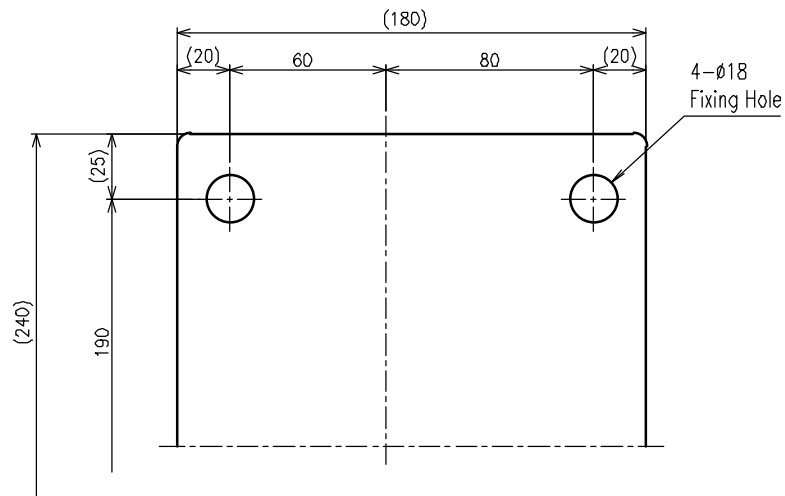

>Specification
Product Weight = 23kg
Load Capacity = 2000kgf

Head = S45C
Body = FC250